

RxMUX Configuration for up to 8 Outputs

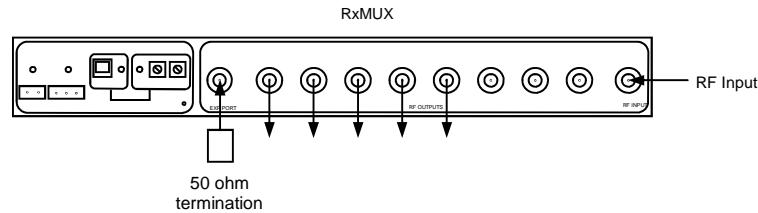

Diagram shows 5 RF Outputs each with a gain of 0 to +15dB

RxMUX Configuration for up to 16 Outputs

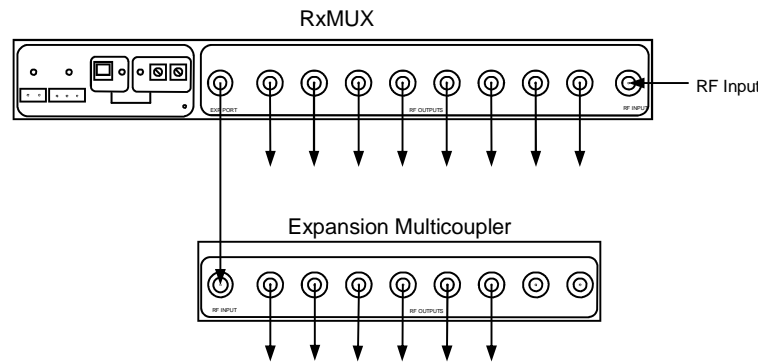

Diagram shows 14 RF Outputs each with a gain of 0 to +15dB

RxMUX Configuration for up to 64 Outputs

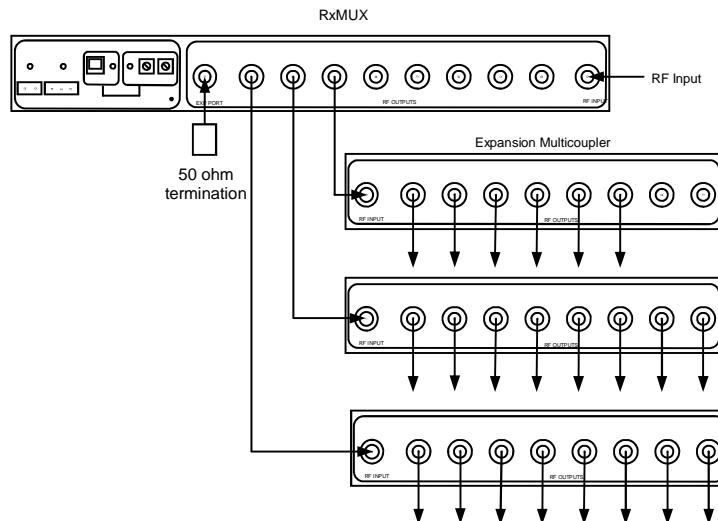

Diagram shows 22 RF Outputs each with a gain of -10 to +5dB

RX1317-3408-31 RX3852-3408-31 RECEIVER MULTICOUPLER

Quick Start Guide



INTRODUCTION

The RFI Receiver Multicoupler (RxMUX) is a low noise, high intercept point active multicoupler designed to distribute signals from a single antenna to multiple receivers. The gain can be set locally using the Gain Switches or remotely via the USB interface. System status can be remotely monitored via the USB interface with local indication of power, fault and control status given by LEDs on the front and back panels. DC operation is standard with an optional external AC to DC power supply available for AC operation.

INSTALLATION

Mounting

The RxMUX is to be mounted indoors only. It is designed to fit in a 1U rack space and should be mounted clear of any equipment that generates excess heat. Do not mount the unit inside small unventilated enclosures. Continuous operation above the specified maximum temperature may lead to premature failure of the RxMUX.

DC Power

Power the unit from any convenient external supply that can provide the appropriate voltage and current (see serial number label on product). The DC power input is reverse polarity protected.

AC Power

The optional AC plug pack is supplied with a two way Phoenix plug. This should be mounted safely in a convenient location and clear of any equipment or obstructions which may cause it to overheat.

Alarm Connector

A three way Phoenix plug is provided to connect the alarm relay to an external alarm. There is a short circuit between the contacts marked "NC" and "COM" and an open circuit between the centre pin and "COM" when the RxMUX is unpowered. These connections change over when power is applied and there are no faults.

Earthing

Connect an earthing strap from the chassis to an appropriate earth point to protect the RxMUX from being exposed to high transient voltages.

RF Input

The specified maximum signal level into this input should be observed to avoid damaging the input amplifier.

RF Outputs 1 to 8

Eight equal level N connector RF outputs are available. Best performance will be achieved if 50 ohm terminations are fitted to any unused RF outputs however, as the outputs are well isolated from each other, the performance degradation is minimal if the unused RF outputs are left unterminated.

Expansion Port

This port is provided to connect to an optional Expansion Multicoupler. If the optional Expansion Multicoupler is not fitted it is important to fit a 50 ohm termination to the Expansion Port. If it is not terminated the RxMUX performance will be significantly degraded.

Cabling and RF Connections

Please ensure that antenna connections to the unit are properly grounded to avoid lightning transients travelling to the unit.

USB Drivers

A USB driver CD is provided with the RxMUX. When the RxMUX USB cable is first plugged into your PC you will be asked to install new drivers. Insert the CD into your PC and browse to the driver folder in the "USB Drivers" folder. It is usually necessary to install the drivers several times as two different drivers are included in the software package.

OPERATION

Green Power LED

The green LED is active when external power is present. If the green LED is not on then either there is no DC voltage present or the polarity is incorrect.

Red Fault LED

The red LED will come on under the following circumstances.

- The input voltage is either too high or too low.
- The internal power rails are outside their normal operating range.
- The internal amplifier currents are outside their normal operating range.

Yellow Control Mode LEDs

The yellow LEDs indicate which control mode is active. If the "USB" LED is on then the gain will be determined by a setting stored in internal memory which can be changed via the USB interface. If the "Switch" LED is on then the gain will be determined by the setting on the two rotary switches on the back of the unit. If the yellow LED is blinking then a value outside the units gain range has been set on the switches and the gain will be 0 dB.

USB Control Mode

A USB type B connector is provided on the back panel. With a terminal program running on the PC (e.g. HyperTerminal), it is possible to communicate with the RxMUX to change the gain setting and monitor internal faults and voltages.

Switch Control Mode - Gain Setting

Two rotary switches are provided to set the gain of the RxMUX between 0 dB and the Maximum Gain. One is labeled "x10" which steps the gain in 10 dB steps and the other "x1" which steps the gain in 1 dB steps.

e.g. For a RxMUX with a Maximum Gain=15 dB the gain will increase from 0 dB with the switches set to "00" to 15 dB with the switches set to "15". For all switch settings outside the 0 to 15 dB range the gain will be 0 dB.

Software Commands

HELP	Displays a summary of available commands.
SET GAIN {x}	Sets gain between 0 dB and the maximum gain.
SET CONTROL {USB SW}	Selects control mode.
SET NAME {name}	User can enter the site name or other information.
SHOW ID	Displays name, version and serial number.
SHOW STATUS	Displays gain and fault information.
START	Resets the screen.

Resetting the RxMUX to Switch Control Mode

If the RxMUX is in USB control mode but the user does not have access to a computer, the unit can be forced into Switch Control mode by setting the two rotary GAIN switches to "99" and cycling the power.

Operating Precautions

- There is no On/Off switch on the unit - it becomes active as soon as DC power is connected or the AC plug pack is switched on at the AC outlet.
- Do not operate the unit outside the specified operating temperature range.
- Do not open the unit as there are no user serviceable parts inside. All faulty equipment should be returned to RFI for repair.

Specifications - Typical at 25°C

Frequency range	RX1317 132-174 MHz RX3852 380-520 MHz	Max input signal - damage	0 dBm
Gain - RF outputs 1-8	15 dB	Temperature range	-30 to +60 °C
Gain - Expansion Port	25 dB	Power supply options	DC 11 - 16 VDC 18 - 36 VDC 36 - 60 VDC
Gain range	0 to 15 dB	AC	100 - 240 VAC
Gain step size	1 dB	DC current drain	700 mA
Noise figure	2 dB	Reverse polarity protection	Yes
Internal amplifier OIP3	44 dBm	Alarm Relay contact rating	1 A, 60 V
Input/Output return loss	>14 dB	Expansion Multicoupler gain	-10.5 dB
Isolation between outputs	>20dB		

User Manual

For more detailed information on the hardware installation and software commands see the User Manual contained on the CD accompanying this product.

Help

For help on using this product contact your nearest RFI Sales Office.