



User's Manual

MSxxxx-0x05-SP Series

VHF MiniSystem Combiner (Single Antenna System)

Base Line 1.01

Document Number: INS41925-1

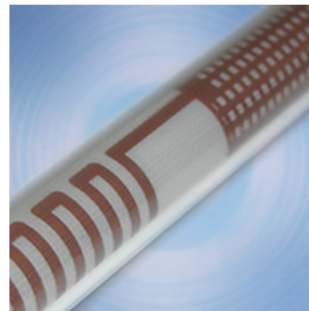

Company Overview

RFI has been serving the needs of the wireless communications market for over 30 years. First founded as a manufacturer of antenna systems, RFI has grown to be a key player in the development, manufacturing and distribution of wireless technology and energy products. Through our extensive network of resellers, systems integrators and retail outlets, RFI is a key supplier to both industry and Government.

Our research and manufacturing facilities have talented people, sophisticated test equipment, state of the art software with class leading manufacturing systems and techniques. Additionally, we have in place a quality management program which is certified to ISO9001, environmental management system certification to ISO14001 and occupational health and safety standard AS4801 giving you complete confidence in everything we do.

RFI's products are truly innovative and as a result we are active around the globe taking our Australian designed and manufactured products to key markets in Asia Pacific, the Americas and EMEA regions via offices 'in-region' in addition to exporting directly to in excess of 50 countries.

One of RFI's key principals is to remain totally customer focused as we recognise our future depends on the success of our customers. We know that to be chosen as your supplier we must add value to your business and to achieve this we will work hard to deliver the best product when and where you need it and back this up with the very best technical support available.

Document Number INS41925-1 Copyright © 2014 RF Industries Pty Ltd First Printing: 04 th October 2014	
Version Number	Version Date
1.00	27 th November 2014
1.01	14 th May 2015

Disclaimer

Product part numbering in photographs and drawings is accurate at the time of printing. Part number labels on RFI products supersede part numbers given within this manual. Information is subject to change without notice.

TABLE OF CONTENTS

1. GENERAL DESCRIPTION	6
2. ELECTRICAL AND MECHANICAL SPECIFICATIONS.....	8
3. ORDERING INFORMATION.....	10
4. UNPACKING.....	11
5. FIRMWARE LICENSE AGREEMENT.....	12
6. SYSTEM INTERCONNECTION DIAGRAM.....	13
7. INSTALLATION.....	14
8. OPERATION	16
9. COMMISSIONING.....	17
10. CONNECTORS, CONTROLS AND INDICATORS.....	19
11. MAINTENANCE, INSPECTION AND REPAIR ADVICE.....	20
12. BACKGROUND MATERIAL AND OTHER RESOURCES	21
13. FREQUENTLY ASKED QUESTIONS (FAQ).....	22
14. USER NOTES:.....	23

Notice

The information contained in this document is subject to change without notice.

RF Industries Pty. Ltd. makes no warranty of any kind with regard to this material, including but not limited to, the implied warranties of merchantability and fitness for a particular purpose. RF Industries Pty Ltd shall not be liable for errors contained herein or for incidental or consequential damages in connection with the furnishing, performance or use of the material.

All information contained in this manual has been reviewed. However RF Industries Pty Ltd accepts no liability for any omissions, errors or construed information.

© 2014, RF Industries Pty Ltd. All rights reserved. Reproduction, adaptation or translation without prior written permission is prohibited except as allowed under copyright laws.

For further information or assistance with this product contact your nearest RFI sales office or through the following;

Region	USA	EMEA	ASIA PACIFIC
Sales email	webmaster@rfi.com.au	sales@rfiemea.com	webmaster@rfi.com.au
Tech Support	support@rfi.com.au	support@rfi.com.au	support@rfi.com.au
Telephone Intl	+1 (330) 486 0706	+44 1869 255 772	+61 7 3621 9400
Telephone local	330 486 0706	01869 255 772	1300 000 RFI
Fax Intl	+ 1 (330) 486 0705	-	+61 2 9630 0844
Web	rfiamericas.com	rfiemea.com	rfi.com.au

MSxxxx VHF Series MiniSystem Combiner

1. General Description

The MSxxxx-0x05-SP VHF MiniSystem Combiner (MSC) series is a full featured, high performance, RF combining solution packaged in a compact 19inch rack mount enclosure that simplifies the system design, procurement, installation and maintenance of RF combining for network applications requiring 1-4 channels of RF combining.

The MiniSystem Combiner comprises a multi-channel transmit (Tx) combiner, a multiple output receiver (Rx) multicoupler, and a bandpass duplexer to interface the Tx and Rx RF paths to a single (Tx/Rx) antenna system.



Transmit (Tx) Combiner

The MiniSystem Combiner uses an innovative “shared load” hybrid combiner architecture to combine the multiple transmit frequencies into a single RF path. Dual-stage, low loss, broadband isolators on each Tx input provide excellent Tx-Tx channel isolation and optimum intermodulation (IM) suppression.

The transmit combiner is designed for full output power on all input channels simultaneously, at 100% duty cycle and across the rated operating temperature range. Its integrated design also provides full protection, at full TX input power, for any antenna VSWR fault condition – including an open circuit state.

The output of the hybrid combiner is filtered using a full bandpass duplexer, for transmit broadband noise suppression and the prevention of receiver desensitisation, prior to connection to the antenna.

Receive (Rx) Multicoupler

Receive (Rx) signals from the antenna are preselected and filtered using a full bandpass duplexer, for transmit carrier rejection and the prevention of receiver overload (blocking), prior to connection to the low-noise amplifier (LNA).

This receiver amplifier's exceptional low noise figure optimises the sensitivity of the connected network base stations, and excellent linearity and third order intercept (3OIP) performance enhances intermodulation rejection within the receive sub-system. The LNA's gain is user-configurable, allowing the adjustment of overall receiver sub-system gain for the optimisation of network sensitivity at sites where high receive distribution cabling losses encourages additional Rx multicoupler gain.

The output of this LNA is connected to an output distribution divider for the distribution of network receive signals to the connected base station receivers.

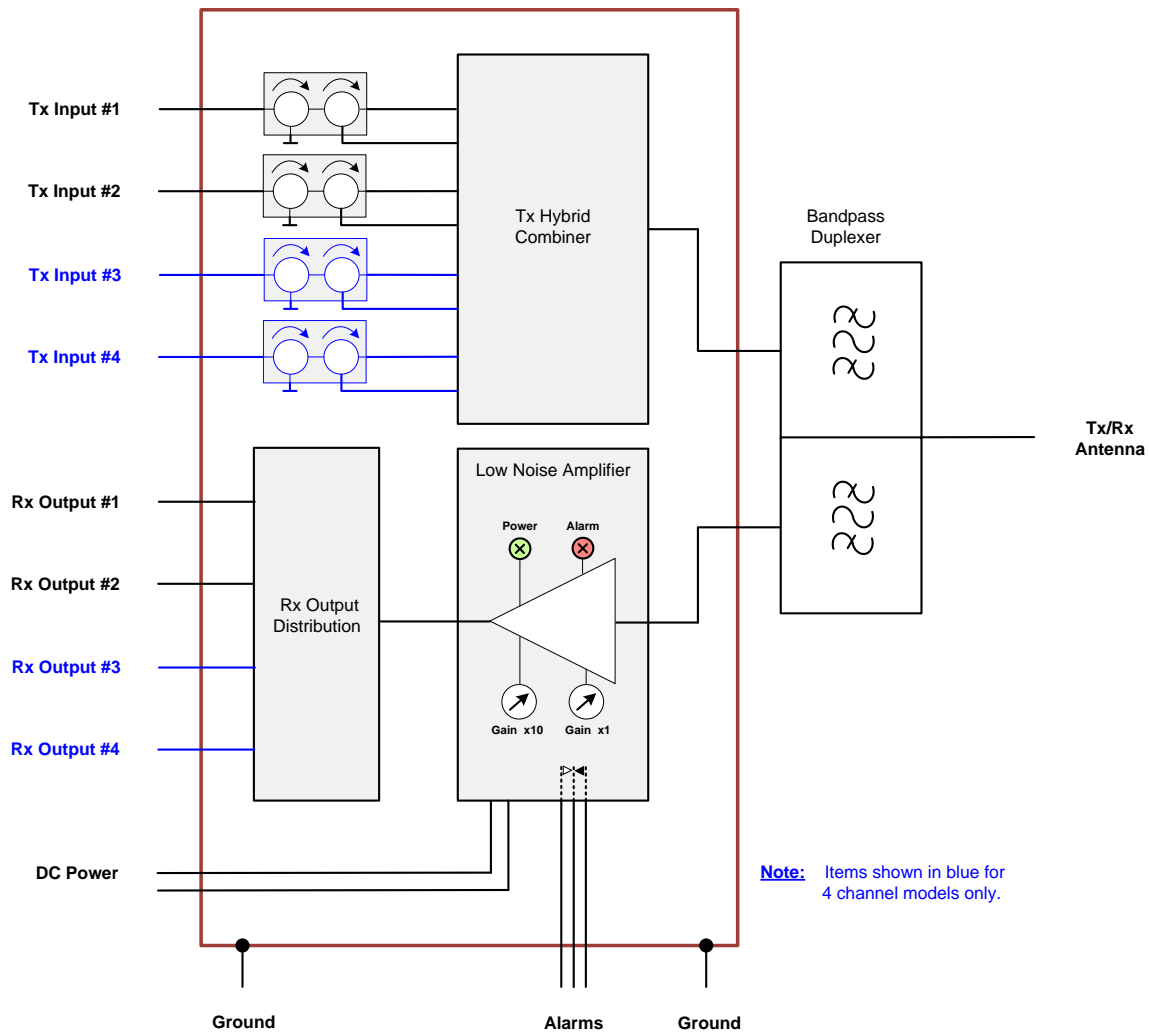

Figure 1 – 4 Channel MiniSystem Block Diagram

Power Supply and Alarm Monitoring

The MiniSystem Combiner features a wide input range DC power supply, with receiver LNA and DC power supply failure monitoring. Form-C dry relay contacts are provided, allowing connection of reported alarms to an external site alarm monitoring system.

100-240VAC Mains Power operation is available using an optional plug pack adapter.

Grounding

There are two grounding studs located on the left-hand and right-hand corners of the rear panel, for compatibility with different racking cabling layout preferences.

Supporting Documentation

Supporting documents including this User's Manual, a Quick Start Guide (QSG) and Application Note are also available from RFI.

2. Electrical and Mechanical Specifications

VHF 2 Channel

Model MSxxxx-0205-SP	1313	1314	1415	1516	1517	1616	1617
Frequency Range (MHz)	132-142	138-148	148-158	155-165	151-172	160-170	164-174
Tx Channel Capacity	≤2						
Tx Input Power	≤ 50Watts						
Tx Duty Cycle	≤ 100%						
Tx-Tx Bandwidth	1.0MHz						
Tx Insertion Loss	<6dB						
Tx-Tx Isolation	>60dB						
Tx Input Return Loss	>20dB						
Tx-Antenna Isolation	>50dB						
Tx-Rx Separation	4MHz min.	4MHz min.	4MHz min.	4MHz min.	21MHz min.	4MHz min.	4MHz min.
Tx-Rx Isolation	65dB min. (70dB typ.)						
Rx Channel Capacity	≤2						
Rx-Rx Bandwidth	1.0MHz						
Rx System Gain	0dB to 30dB (in 1dB steps)						
Rx-Rx Isolation	>18dB						
Rx LNA Noise Figure	1.2dB typ.						
Rx Max. RF Input Level	-10dBm						
Rx Output Return Loss	>20dB						
Impedance	50ohms						
Alarms	DC Supply Voltage Low, Rx LNA Fail						
Alarm Outputs	Dry Relay Form-C (N.C. / N.O. / CMN)						
Alarm Relay Ratings	50VDC 1A max.						
RF Connectors	Tx = N (female) Rx = BNC (female) Antenna = N (female)						
DC Connector	2pin 5mm Phoenix (mating plug supplied)						
Alarm Connector	3pin 5mm Phoenix (mating plug supplied)						
Enclosure	7RU 19in Rack Mount (Black)						
DC Power Requirements	+11VDC to +28VDC 3.5W typ. (polarity protected)						
Grounding	5mm and 6mm stainless steel studs						
IP Rating	Indoor Use Only						
Operating Temperature	-30° to +60° C (-122° to +140° F)						
Dimensions (HxWxD)	313x483x430mm (12.33x19x17in)						
Weight	18.5Kg (40.7lbs)						

Table 1

Note: The 1517 model is designed for use for the special mining industry 21MHz Tx-Rx separation.

VHF 4 Channel

Model MSxxxx-0405-SP	1313	1314	1415	1516	1517	1616	1617
Frequency Range (MHz)	132-142	138-148	148-158	155-165	151-172	160-170	164-174
Tx Channel Capacity	≤4						
Tx Input Power	≤ 50Watts						
Tx Duty Cycle	≤ 100%						
Tx-Tx Bandwidth	1.0MHz						
Tx Insertion Loss	<9dB						
Tx-Tx Isolation	>60dB typ.						
Tx Input Return Loss	>20dB						
Tx-Antenna Isolation	>50dB						
Tx-Rx Separation	4MHz min.	4MHz min.	4MHz min.	4MHz min.	21MHz min.	4MHz min.	4MHz min.
Tx-Rx Isolation	65dB min. (70dB typ.)						
Rx Channel Capacity	≤4						
Rx-Rx Bandwidth	1.0MHz						
Rx System Gain	0dB to 30dB (in 1dB steps)						
Rx-Rx Isolation	>18dB						
Rx LNA Noise Figure	1.2dB typ.						
Rx Max. RF Input Level	-10dBm						
Rx Output Return Loss	>20dB						
Impedance	50ohms						
Alarms	DC Supply Voltage Low, Rx LNA Fail						
Alarm Outputs	Dry Relay Form-C (N.C. / N.O. / CMN)						
Alarm Relay Ratings	50VDC 1A max.						
RF Connectors	Tx = N (female) Rx = BNC (female) Antenna = N (female)						
DC Connector	2pin 5mm Phoenix (mating plug supplied)						
Alarm Connector	3pin 5mm Phoenix (mating plug supplied)						
Enclosure	7RU 19in Rack Mount (Black)						
DC Power Requirements	+11VDC to +28VDC 3.5W typ. (polarity protected)						
Grounding	5mm and 6mm stainless steel studs						
IP Rating	Indoor Use Only						
Operating Temperature	-30° to +60° C (-122° to +140° F)						
Dimensions (HxWxD)	313x483x430mm (12.33x19x17in)						
Weight	22.5Kg (49.5lbs)						

Table 2

Note: The 1517 model is designed for use for the special mining industry 21MHz Tx-Rx separation.

3. Ordering Information

Ordering Information	
RFI Part Number	Description
MS1313-0205-SP	132-142MHz - 2 Ch MiniSystem Combiner – Single Antenna operation – with Rx Preamplifier
MS1314-0205-SP	138-148MHz - 2 Ch MiniSystem Combiner – Single Antenna operation – with Rx Preamplifier
MS1415-0205-SP	148-158MHz - 2 Ch MiniSystem Combiner – Single Antenna operation – with Rx Preamplifier
MS1516-0205-SP	155-165MHz - 2 Ch MiniSystem Combiner – Single Antenna operation – with Rx Preamplifier
MS1517-0205-SP	151-172MHz - 2 Ch MiniSystem Combiner – Single Antenna operation – with Rx Preamplifier
MS1616-0205-SP	160-170MHz - 2 Ch MiniSystem Combiner – Single Antenna operation – with Rx Preamplifier
MS1617-0205-SP	164-174MHz - 2 Ch MiniSystem Combiner – Single Antenna operation – with Rx Preamplifier
MS1313-0405-SP	132-142MHz - 4 Ch MiniSystem Combiner – Single Antenna operation – with Rx Preamplifier
MS1314-0405-SP	138-148MHz - 4 Ch MiniSystem Combiner – Single Antenna operation – with Rx Preamplifier
MS1415-0405-SP	148-158MHz - 4 Ch MiniSystem Combiner – Single Antenna operation – with Rx Preamplifier
MS1516-0405-SP	155-165MHz - 4 Ch MiniSystem Combiner – Single Antenna operation – with Rx Preamplifier
MS1517-0405-SP	151-172MHz - 4 Ch MiniSystem Combiner – Single Antenna operation – with Rx Preamplifier
MS1616-0405-SP	160-170MHz - 4 Ch MiniSystem Combiner – Single Antenna operation – with Rx Preamplifier
MS1617-0405-SP	164-174MHz - 4 Ch MiniSystem Combiner – Single Antenna operation – with Rx Preamplifier
RX0000-3000-AC	100-240VAC / 12VDC Mains Power Plug Pack Power Supply
SP0000-6001-11	50ohm BNC (male) Termination for unused Rx Output ports
SP0000-6002-11	50ohm N (male) Termination for unused Tx Input ports

Table 3

Note: The 1517 model is designed for use for the special mining industry 21MHz Tx-Rx separation.

4. Unpacking



CAUTION: Take all necessary precautions when lifting heavy items. Incorrect lifting of heavy weights can cause injury. Seek assistance, or use approved lifting devices for safety.

The MiniSystem Combiner is packed and shipped in cardboard packaging. Packed with the unit will be the Factory Test Sheet (FTS), Quick Start Guide (QSG) and User's Manual. Supporting documentation is also available from the RFI website at www.rfiwireless.com.au.

The packaging used will provide suitable product protection during shipping. However, it is important to report any visible damage to the outside of the packaging to the carrier *immediately* upon delivery.

It is the customers' responsibility in the event of product damage, to lodge a damage claim with the carrier within a short period of time after receipt of the package. The time window for lodging the claim should be ascertained from the specific carrier as this may vary between carriers (typically 1 to 5 days).

Please dispose of all packaging material responsibly.



RECOMMENDATION: Please retain and file all Factory Test Sheets and ongoing Periodic Maintenance Inspection results for future reference.

The Factory Test Sheet (FTS) is a reference document that represents the MiniSystem Combiner performance at the time of manufacture.

It is recommended to retain and file the Factory Test Sheet, and any results of ongoing Periodic Maintenance Inspection (PMI) or other maintenance activities' testing, to enable the ongoing performance of the MiniSystem Combiner to be assessed and verified.

5. Firmware License Agreement

This statement must be read in its entirety prior to the loading or use of the Firmware provided by RFI in this product.

Introduction.

By using or uploading any product related Firmware you agree without reserve with all the conditions as detailed in this RFI Firmware License Agreement.

The term "Firmware" for the sake of this statement includes all software or firmware upgrades, either as a new installation, revision, patches or upgrades. Any reference to software, for the purposes of this license agreement, will therefore be included in the term Firmware.

RFI refers to the Australian registered company RF Industries Pty Ltd.

The copyright of all Firmware relating to this product remains the property in whole of RFI and is therefore protected by the respective international copyright or trademark laws.

You agree that by using and or downloading any of the RFI product specific Firmware, that you have fully understood and agree to comply and be bound by the all of the conditional requirements as detailed in this Firmware License Agreement and accept the disclaimer thereof.

RFI reserves the right to update and change, from time to time, any attribute, function, feature and in the main any content of the Firmware and any documentation attributed and referenced to the Firmware underwritten by this Firmware License Agreement without notice to existing users.

The use of this Firmware is non-exclusive and non-sub licensable, nor does it give the user the right to re-sell, lease, loan, distribute, or transfer the Firmware nor the rights thereof.

This Firmware License Agreement grants or implies no right, title, or interest in any intellectual property owned or licensed by RFI.

Support and Firmware Updates.

RFI may elect to provide you with customer support and/or Firmware upgrades, enhancements, or modifications for the RFI Firmware at its sole discretion, and may terminate such support at any time without notice to the user. RFI may change, suspend, or discontinue any aspect of the Firmware at any time, including the availability of any Firmware feature, database, or content.

From time to time RFI may provide notice through the RFI web site of any available updates or Firmware revision downloads.

Fees.

RFI reserves the right to charge fees for upgrades or revisions of the applicable Firmware download.

Disclaimer.

Use of any Firmware enabling operation of the product or providing support for the product is at the user's discretion and risk. RFI will not be held responsible or liable for any damage or loss that results from the downloading and or use of the Firmware or incompatibilities or other problems experienced as a result of any combination of operating system(s), firmware, or software the user may use.

RFI will not be held responsible or liable for any inaccuracies, completeness or inadequacy regarding the Firmware as the basis of the provision of the Firmware is on a "fit-for-purpose, best effort" approach.

RFI will not be liable to the user for claims and liabilities of any kind arising out of or in any way related to the use of the Firmware by the user or any third party.

The failure of RFI to exercise or enforce any right or provision of this Firmware License Agreement shall not constitute a waiver of such right or provision.

6. System Interconnection Diagram

MiniSystem Combiners are designed to be used in a range of channel capacity configurations to suit from 1-4 RF channels. The following system diagram shows the interconnections between the network base station equipment, antenna system and MiniSystem Combiner;

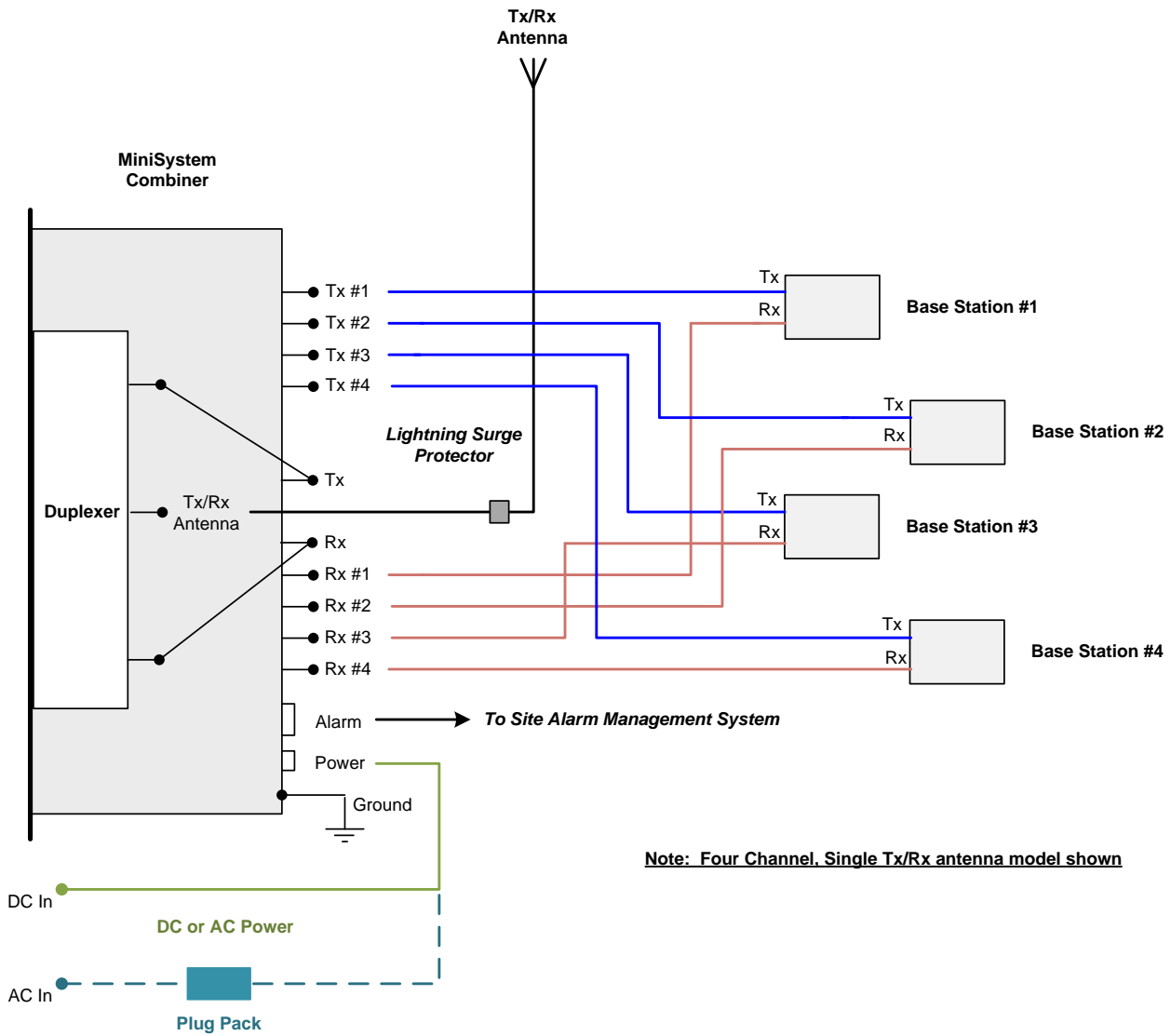

Figure 2 – MiniSystem Combiner System Interconnection Diagram

7. Installation



CAUTION: All installation works should be conducted by qualified personnel and in compliance with recognised standards, workplace safety, and best engineering practices.

General

The use of appropriate installation mounting hardware that suits the specific racking or other installation style is important.

The MiniSystem Combiner is designed to be installed into standard 19inch rack mount frames or cabinet spaces. Install the unit using four screws that match the 19in racking, ensuring nylon washers are used under the head of the screws to protect the MiniSystem Combiner front panel.



Figure 3 – MiniSystem Combiner

To cater for the variety of installation locations and mounting systems, some screws, washers or other miscellaneous hardware items required to complete those installations may need to be supplied by the customer or their installation contractor.

An M6 stud and M5 grounding stud are located on the rear of the MiniSystem Combiner for earthing to the site's lightning protection grounding system with an earthing strap or cable. Both flat and lock washers are supplied on these grounding studs to ensure the cabling can be firmly secured for optimum grounding connection integrity.

This site lightning protection grounding system should be bonded back to the building cable entry bulkhead panel (Refer to Figure 5).

Interconnecting Cabling

Connect the Base Station transmitters and receivers to the Tx Input and Rx Output ports on the rear of the MiniSystem Combiner using high quality coaxial cable (solid or double-shielded jacket type). The type of interconnecting coaxial feeder cables that may be used between the MiniSystem Combiner, the Base Stations, and Antenna system may vary, but generally their type will be determined by their length and resulting insertion loss.

Unused RF ports on the MiniSystem Combiner should be terminated with 50ohm terminations.

For the MiniSystem Combiner power supply, a cable from the chosen DC power source should be terminated into the supplied 2-pin plug, observing the correct polarity, and then plugged into the polarised 2-pin socket on the rear of the MiniSystem Combiner. For AC Mains powered versions, an AC-to-DC plug pack is available (as an option) with a pre-terminated 2-Pin plug. This should be fitted into the polarised 2-pin socket on the rear of the MiniSystem Combiner.

Lightning Protection

Lightning protection and grounding of the MiniSystem Combiner and its associated network equipment is important. A lightning suppressor with appropriate operating frequency and power ratings, and suited for multi-carrier combiner operation, should be fitted to the antenna system at the equipment building entry point. This lightning suppressor should be connected to an appropriately designed and installed site lightning grounding system.

Grounding

Compliance with international electrical safety standards requires that the external Protective Earthing point on this equipment, as indicated by this symbol, be permanently hardwired to the premise's protective earth system using a 1.5mm² (14AWG) minimum cross-sectional area conductor. This connection provides protection from hazardous and transient voltages.



Cable grounding kits, cable installation hardware, antenna mounting hardware and antenna type(s) should be selected to suit the network site, the antenna tower (or building, etc), and network coverage required from the site.

NOTE: RFI can provide information and support in the selection of cable, connectors, lightning protectors, cable grounding kits, antennas and related installation items required to support the use of the MiniSystem Combiner.



Figure 4 – Typical Lightning Protector

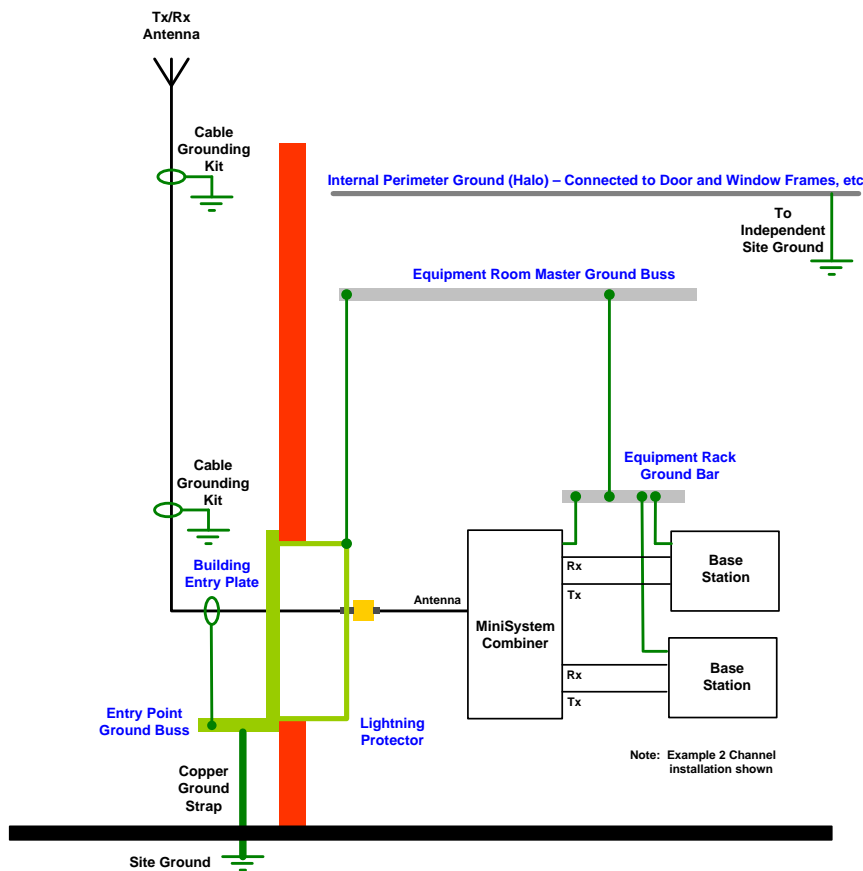



Figure 5 – Lightning Protection and Site Grounding Recommendations



WARNING: Failure to provide adequate lightning protection and grounding may result in equipment failure caused by electrical surge damage.

Installation Summary

The provision of adequate lightning protection, correct grounding, the appropriate torquing of connectors and the sealing of terminations are all important elements of any system installation.

Careful attention should be given to these areas of the installation to ensure optimum system performance and prolonged equipment life.

8. Operation

Supporting documents including this User Manual, a Quick Start Guide (QSG) and Application Note are supplied with the MiniSystem Combiner.

When the MiniSystem Combiner has been installed and connected to the interconnecting coaxial cables to the network base stations and antenna system, the power source to the MiniSystem Combiner may be connected and switched on.

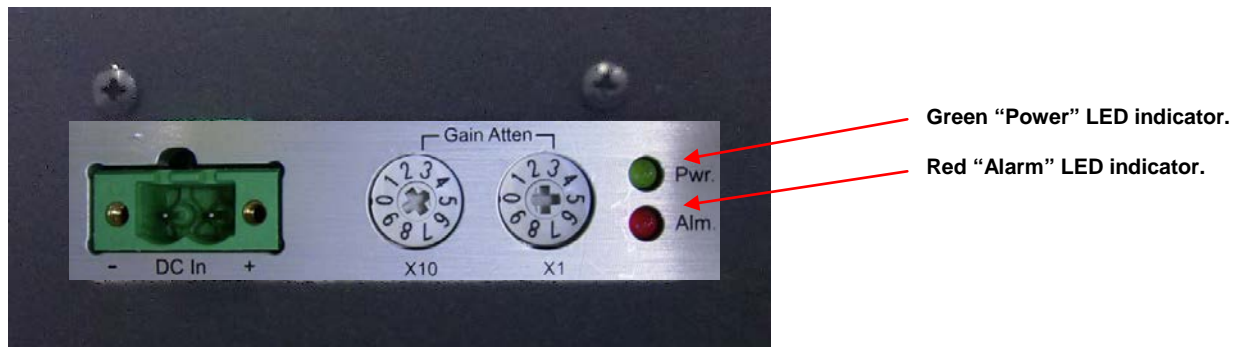

Figure 6 – Power and Alarm LED indicators

Check that the green “Power” LED indicator on the MiniSystem Combiner rear panel is illuminated, and that the adjacent red “Alarm” LED indicator is not illuminated.

The MiniSystem Combiner is now ready for commissioning and operation.

9. Commissioning

General

It is important that the MiniSystem Combiner is commissioned correctly to ensure that optimum system performance is achieved from the connected network base station equipment. The following process outlines the correct procedure for configuring the *Nett Receive System Gain*, and is designed to standardise the installation of these systems.

Low Noise Amplifier (LNA) Attenuator Settings:

The MiniSystem Combiner LNA provides user-configurable attenuators for setting the *Nett Receive System Gain*. These attenuators are set in the RFI factory during testing to provide a 0dB (unity) nett gain, or as close to this as possible as determined by the available 1dB attenuator steps, and this initial setting is suitable to use in most installations.

This attenuator setting is referred to as the *RFI Factory Default* setting.

Two attenuators are presented for user configuration; a "tens" (X10) setting, and a "units" (X1) setting. A small arrow shape can be seen in the adjustment slot on each attenuator (refer Figure 7), and this arrow points to the associated value represented in the currently selected position.

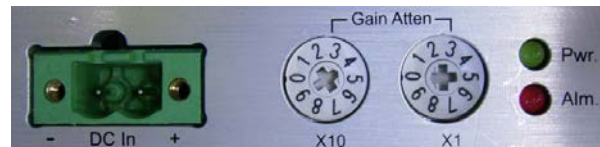

Figure 7 – Gain Attenuators (40dB shown)

These slots should be adjusted carefully, with a well-fitting adjustment tool, to prevent damaging the attenuators.

Nett Receive System Gain	"X10" tens setting	LNA "X1" units setting
~ 0dB	1	0
1dB	1	1
2dB	1	2
3dB	1	3
4dB	1	4
5dB	1	5
6dB	1	6
7dB	1	7
8dB	1	8
9dB	1	9
10dB	2	0
11dB	2	1
Etc	etc	2

Figure 8 – Typical Receive System LNA Gain configuration

The typical gain settings that should be configured on the Receive LNA attenuators can be calculated as follows;

LNA Attenuators setting equals MiniSystem Combiner "Net Receive System Gain" plus 10dB



CAUTION: The correct adjustment of these attenuators is important, as this setting maintains protection of the base station receivers against high level RF signals – while obtaining the optimum available system sensitivity.

Adjusting the Nett Receive System Gain

The gain of the MiniSystem Combiner LNA is primarily used to overcome the loss of the receive output distribution within the MiniSystem Combiner, and the cabling losses between the MiniSystem Combiner Rx Output ports and the connected network base station receivers - with the objective to provide a nett 0dB (unity) gain from the antenna input of the MiniSystem Combiner, to the input of the base station receiver itself.

In most site installations, the network base stations will be mounted in close proximity to the MiniSystem Combiner, so the insertion loss of the cables from the MiniSystem Combiner Rx Output ports through to the base station receiver ports will be negligible.

However, in some installations, the base station equipment may be located some distance from the MiniSystem Combiner, and in these situations the insertion loss of the cable from the MiniSystem Combiner Rx Output ports to the base station receiver port increases the receive output distribution losses. As the length of these distribution cables to individual base stations may vary, an "average" loss should be estimated based on the cable type and typical length (refer to the manufacturers data sheet for values). In such circumstances, it is recommended to increase the MiniSystem Combine LNA gain, proportionally to the "average" loss of these cables, to recover this additional loss.

In the example shown below, the type/length of these distribution cables represents an increased receive output distribution loss of 2dB (average). To recover this 2dB increased distribution loss, the LNA gain should be increased by 2dB above the *RFI Factory Default* attenuator setting.

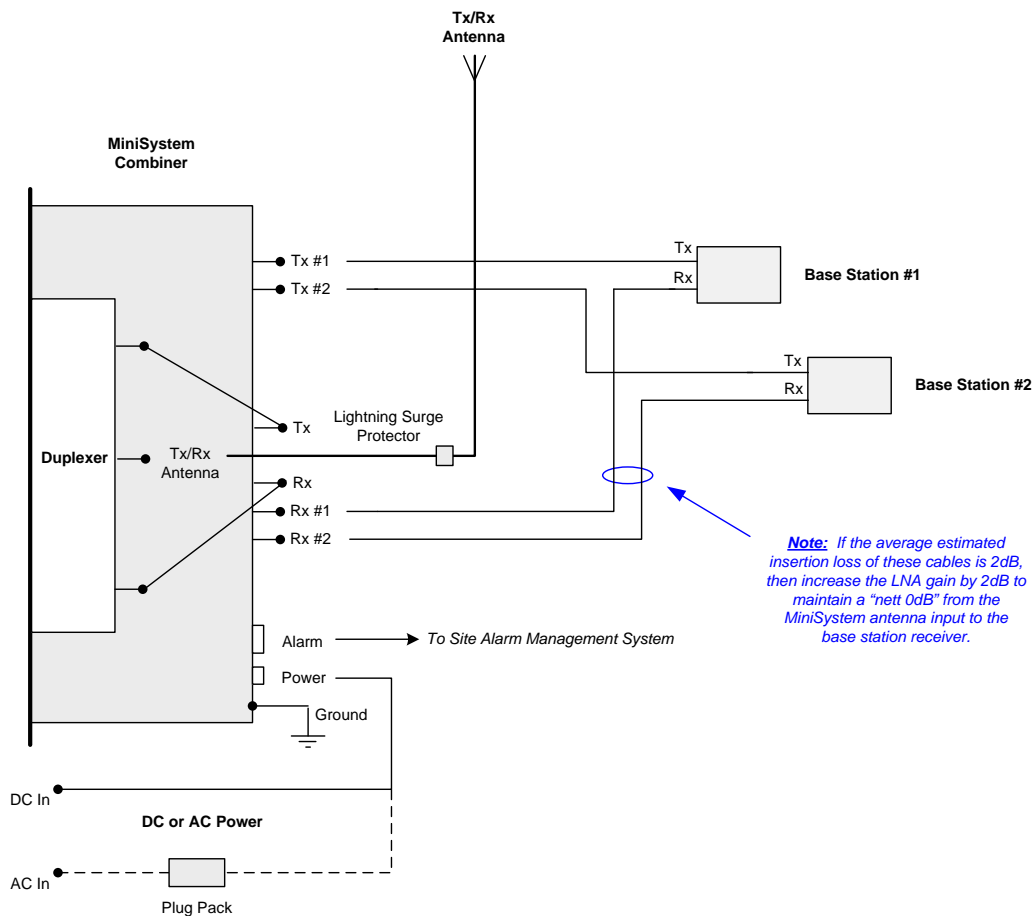

Figure 9 – Adjusting LNA Gain

10. Connectors, Controls and Indicators

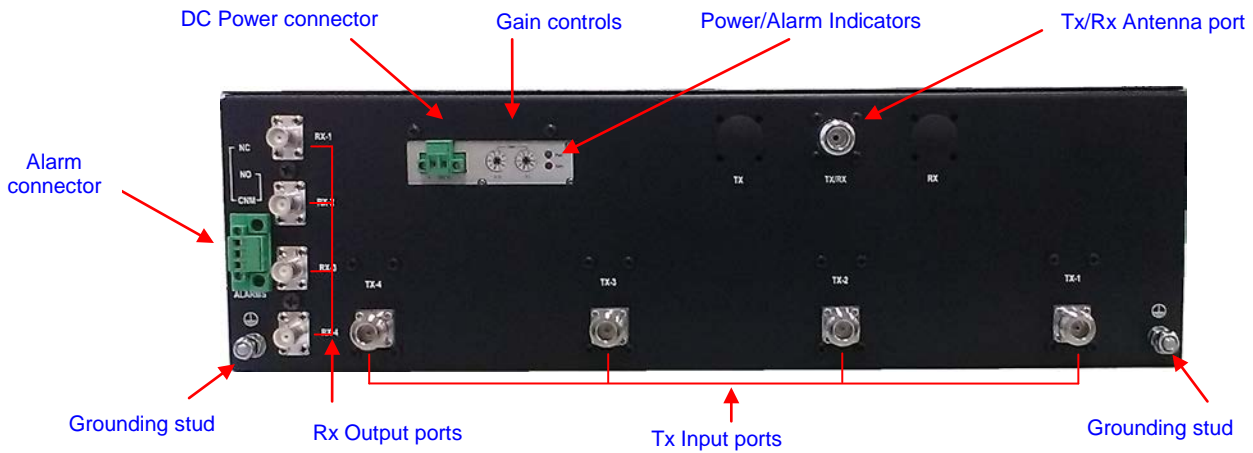

Figure 10 – MiniSystem Combiner Rear Panel layout (4 Channel model shown)

MiniSystem Combiner DC Power connector (Phoenix 2-pin) pin-out:

The pin configuration of the polarised Phoenix 2-pin connector on the rear of the MiniSystem Combiner is illustrated below.



MiniSystem Combiner Alarm connector (Phoenix 3-pin) pin-out:

The pin configuration of the polarised Phoenix 3-pin connector on the rear of the MiniSystem Combiner is illustrated below.

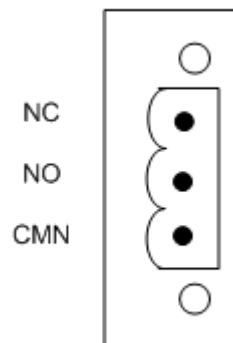

11. Maintenance, Inspection and Repair Advice

No special maintenance program is required for the MiniSystem Combiner. Testing and inspection of the MiniSystem Combiner may be included in a Periodic Maintenance Inspection (PMI) program if desired.

Checking that the RF connectors on all coaxial cables are correctly torqued (as per respective manufacturers' recommendations) is considered good practice during any maintenance visit.

All other connectors (power, alarm, etc) must be firmly located into their corresponding mating sockets, with their fastening screws tightened securely.

The MiniSystem Combiner is considered field repairable at a *module level*. Should any module within a MiniSystem Combiner be considered faulty through diagnosis, then it may be replaced by a qualified maintenance technician - or the complete MiniSystem Combiner may be returned to RFI for repair.

12. Background Material and other resources

For Product Datasheets, User Manuals, Quick Start Guides (QSGs), Application Notes or additional information on the RFI range of MiniSystem Combiners and our other products please visit:

<http://www.rfiwireless.com.au>

13. Frequently Asked Questions (FAQ)

Q – Can the MiniSystem Combiner handle continuously keyed base station transmitters on all channels when the network is heavily loaded with traffic?

A – **Yes.** The MiniSystem Combiner is rated for up to 50Watts of Tx Input power on each channel, and the innovative hybrid combiner design is rated for this Tx Input power at 100% duty cycle on all channels and across the stated operating temperature range.

Q – Does the MiniSystem Combiner need to have a full complement of network base stations fitted?

A – **No.** Only the initial number of channels required on the site need be connected. Unused MiniSystems Combiner Tx Input and Rx Output ports may be left for future site capacity expansions. In this way, a 4 channel combiner could be used, with only 2 channels initially fitted, and the remaining 2 channels of combining capacity left for future network growth.

Q – What is the minimum channel spacing possible on a MiniSystem Combiner?

A – The MiniSystem Combiner uses an innovative hybrid combining technique that can allow adjacent Tx and or Rx frequencies to be connected if desired.

Q – What is the maximum channel spacing possible on a MiniSystem Combiner?

A – All Tx frequencies must be within the Tx-Tx passband width of the bandpass filtering (duplexer) fitted. The Rx frequencies must likewise all be within the Rx-Rx passband width of the bandpass filtering (duplexer) fitted.

Q – What is the minimum Tx-Rx frequency separation possible on the MiniSystem Combiner?

A – **4MHz.** To provide a generic product that can be deployed into the majority of network applications, a 4MHz minimum Tx-Rx spacing specification has been selected and used for the design of the bandpass filter (duplexer) used in the MiniSystem Combiner.

Q – Can the MiniSystem Combiner be expanded?

A – **No.** The MiniSystem Combiner has been released in both 2 channel and 4 channel capacity formats that cater for a wide range of network applications requiring from 1-4 RF channels. The 2 channel model can be used for small network sites of 1-2 channels, and provides an entry level product for small network sites. The 4 channel model can be used for any network site of 1-4 channels, with unused Tx and Rx ports terminated and available for future network expansion requirements.

Q – Are alarms available?

A – **Yes.** The MiniSystem Combiner provides a Form-C dry relay output that provides status monitoring of both DC Input Power and Rx LNA Failure. This alarm relay output may be connected to a Base station's external alarm input, or existing Site Monitoring equipment, to provide MiniSystem Combiner alarm status monitoring and reporting.

14. User Notes:

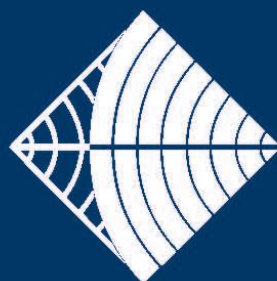

RFI

rfi.com.au

1300 000 734